

Using ACP+ Line Stage with VCX MUSES Volume Control

By Dr. Lenny Novikov

An ACP+ is yet another one of the sweet sounding line stages from Nelson Pass, which can also drive headphones or an efficient speaker.

Those familiar with the transparency and purity of the High-End audio sound also know how much it depends on the quality volume control. One of the great solutions would be to use a resistive ladder with a multi-position rotary switch. While it provides ultimate sonic purity, the large physical size, high cost and the lack of reasonable remote control options renders this solution impractical.

A great audio volume control chip from the NJR MUSES team provides a dual channel resistive ladder with 0.5dB steps and a digital control. It was highly praised and successfully used by Nelson Pass in several highly acclaimed preamps. The VCX and VCM modules from AcademyAudio.com make use of the MUSES72320 chip the cleanest way with no extra elements in the audio path, and provide Volume, Balance and Mute functions from a single knob and a dedicated IR remote control unit.

It is not a coincidence that the ACP+ circuit presents a good match for the MUSES volume control chip. The ACP+ circuit has a JFET input that allows taking full advantage of the low noise and high linearity of the MUSES volume control. This Application Note provides guidelines on how to integrate the VCX MUSES Volume Control board with the ACP+ line stage.

The original ACP+ Circuit

The original ACP+ Line Stage circuit as published by Mr. Pass is shown below at Figure 1.

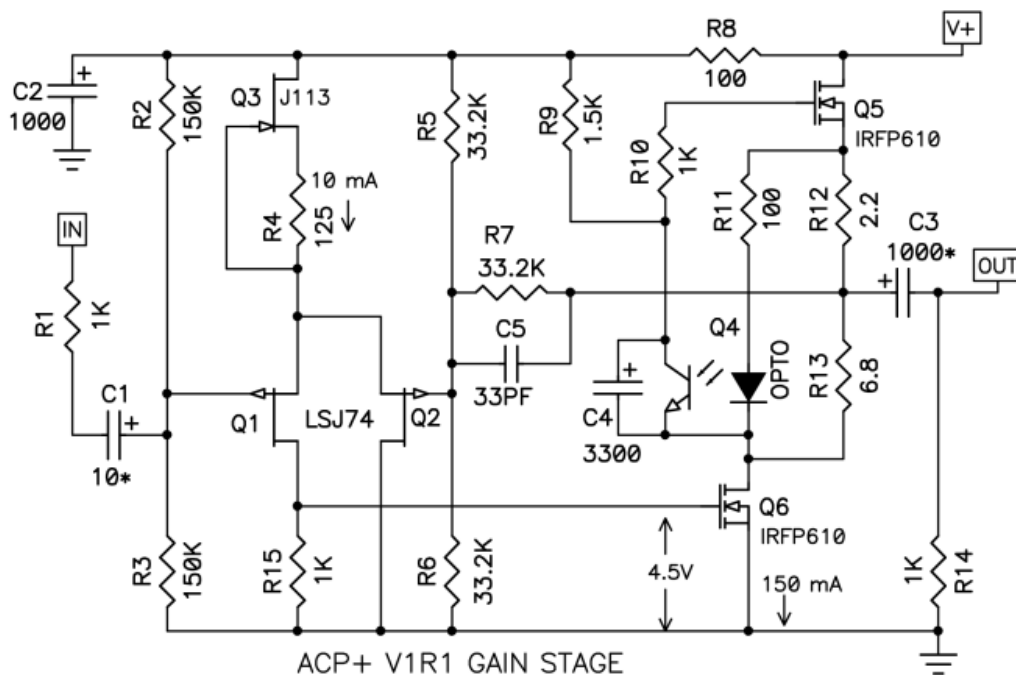

Figure 1. Original ACP+ Line Stage circuit.

Matching the MUSES Volume Control

A MUSES Volume control chip can be presented as a dual 20K digitally controlled potentiometer with a precise logarithmic taper. To preserve the precision of the logarithmic control curve, the input impedance of the circuit immediately following the volume control chip shall be sufficiently high. The table of Figure 2 shows an error magnitude depending on the value of the loading impedance.

| R_load, kOhm | Volume Control Position | |
|-----------------|-------------------------|-----------------|
| | 0dB to -32dB | -32dB to -112dB |
| | Error, dB | Error, dB |
| 10 | -4.08 | -2.28 |
| 20 | -2.28 | -1.21 |
| 47 | -1.04 | -0.54 |
| 100 | -0.51 | -0.26 |
| 200 | -0.26 | -0.13 |
| 1000 | -0.05 | -0.03 |

Figure 2. Volume Control Error.

Note the 150K value of the ACP+ input resistors **R2** and **R3**. According to Table 2, the resulting input impedance of 75K will produce an error of more than 0.5dB. We will need to increase the input impedance to at least 200K. By changing the R2 and R3 values to 470K (1%) the input impedance will be increased to 235K. This change does not affect either the noise floor or the linearity of the ACP+ circuit.

Complete ACP+ /VCX Circuit

The circuit of **Fig. 3** presents a complete dual channel audio preamp solution with a remote control and a digital readout.

The circuit uses a VCX module and an isolated DC-DC converter to power the VCX. An optional muting relay is added to control the power-up/power-down noises.

The proposed arrangement requires minimal changes to the original ACP+ circuit – only two resistors **R2** and **R3** should be changed for both channels.

The circuit is discussed below in greater details.

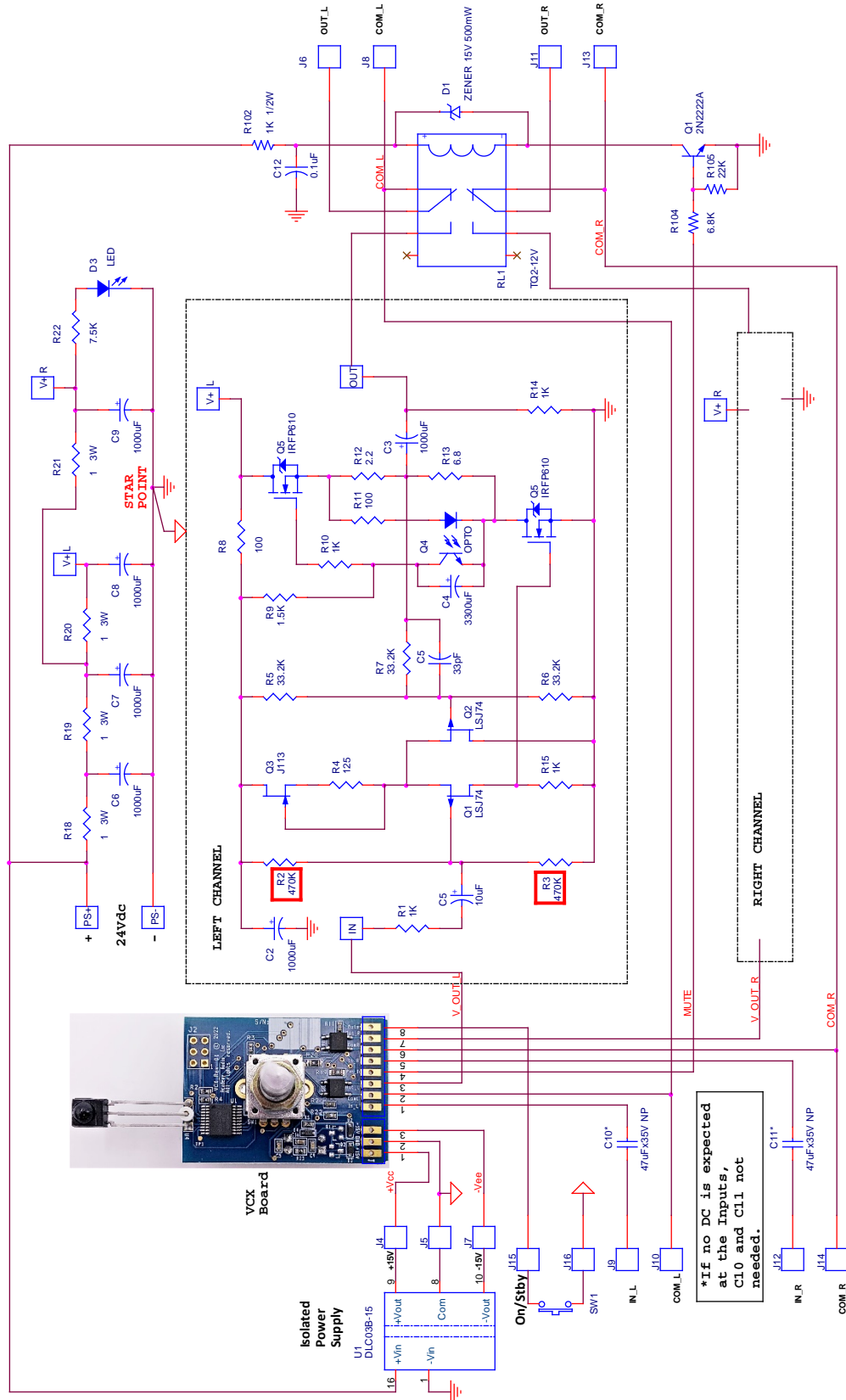

Figure 3. Complete ACP+ / VCX Circuit. Note the On/Standby switch (optional).

Muting Relay Circuit

A Muting relay with a delayed turn on is provided to eliminate possible power-up/power-down noises.

The VCX board provides a control signal (active High) for the Muting relay with a 1.5 seconds delay at start-up and turns off the relay immediately when powered down. Any good quality 12V rated signal relay can be used as RL1. The TQ2-12V non-latching signal relay from Panasonic is widely available and proven to work well for this application. The relay takes less than 12mA to operate and does not degrade sound quality. The proposed circuit was calculated for this particular relay type.

A low power NPN transistor Q1 drives the Muting relay RL1 from the +24V power through the voltage drop resistor R18. A Zener diode D1 with a capacitor C14 take care of the inductive properties of the relay coil.

Any 12Vdc DPDT signal relay with working current less than 60mA can be used in this circuit. R18 value should be adjusted to accommodate the relay current change as follows:

$$R18(\text{Ohms}) = 12\text{V}/(\text{relay current, Amp})$$

The muting relay circuitry is optional and may be omitted if no power-up/power-down noises are observed.



Note on Power Supply



The ACP+ circuit is designed for a single +24V power supply operation, and the VCX requires a dual +/-12V... +/-15V power supply to operate.

While it is possible to redesign the ACP+ for a dual power supply operation, such redesigned circuit would still need the output capacitor C3, due to a small residual DC voltage at the output that could be harmful for the headphones.

A small switching power supply that takes the same 24Vdc on the input and provides the **isolated** dual +/-15Vdc output needed for the VCX operation. The DLC03B-15 from MeanWell (Mouser p/n 709-DLC03B-15) perfectly suits the bill, and can be used without additional filters. The switching noise of this power supply is below 10mV at 25mA output current. Any electromagnetic artifacts that may be picked up by the audio circuitry lie above 100 kHz, and do not affect sonic quality. Any substitute power supply should provide similar specs to achieve comparable sonic results.

Note on Ground Connection

IMPORTANT: We introduced a new signal ground (GND) symbol  , which is **not equivalent** to the ACP+ Ground  .

This signal GND  refers to the output of the isolated dual power supply. For the best sonic results it **must be connected** to the ACP+ Ground  in one point, which is shown on the Fig. 3 schematic as the STAR POINT. **Failure to connect the grounds may result in a failure of the VCX board.**

It is important to use **isolated** RCA connectors for audio inputs and outputs. The audio grounds COM_L and COM_R, which are separate for the LEFT and RIGHT channels, are internally connected to the signal

GND  on the VCX board. Connecting the RCA connectors to the chassis may result in ground loops that can degrade the sound.

Balanced Audio Applications

For a balanced audio application, you can use the VCX+BIB bundle to get balanced audio inputs. Note that the BIB features the Muting relay on board. The DLC03B-15 isolated power supply will power both VCX and the BIB.

Follow the BIB Manual to connect the VCX to the BIB board.

Connect DLC03B-15 isolated power supply to the BIB board as follows:

| | |
|----|---|
| J7 | Vcc=+15Vdc |
| J8 | Signal Ground  |
| J9 | Vee=-15Vdc |

Remove the opamp chip from the BIB board socket in U7 position, and connect the ACP+ board to the test points as follows.

| Test Point | Description |
|-------------------|----------------------|
| TP4 | Left Channel Input |
| TP3 | Right Channel Input |
| TP5 | Left Channel Output |
| TP2 | Right Channel Output |
| J8 | Power GND |

IMPORTANT: J8 **must be connected** to the ACP+ Ground  in one point, which is shown on the Fig. 3 schematic as the STAR POINT. **Failure to connect the grounds may result in a failure of the VCX board.**

Follow the BIB Manual to connect either single-ended output RCA connectors or the Quasi-Balanced audio output XLR connectors.

The use of the true balanced output BOB board requires a more powerful isolated power supply. Consult the factory for the BOB application.

Conclusion

The ACP+ line stage offers a great way to build a great sounding preamp capable of driving headphones, when combined with a MUSES enabled VCX volume control.

Happy Listening!